

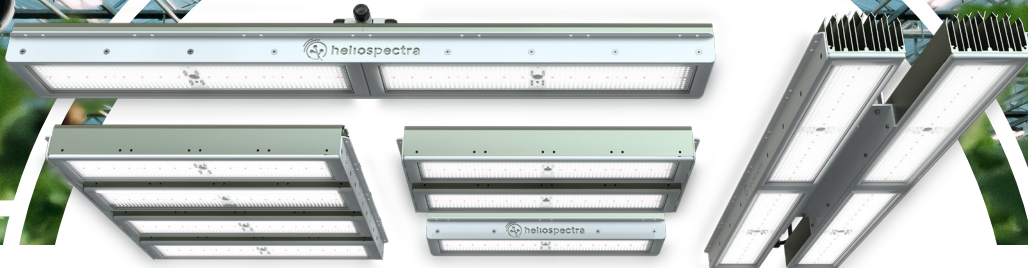

heliospectra



MITRA

User Manual

Heliospectra
Horticulture
Fixtures

Disclaimer

The contents of this document are subject to revision without notice, due to continued progress in methodology, design and manufacturing. Heliospectra AB shall have no liability for any error or damage resulting from the use of this document.

At Heliospectra AB we aim to continuously improve our product documentation. If you have comments or ideas regarding this document, please contact us at support@heliospectra.com.

Copyright and Trademarks

No part of this publication may be reproduced, stored in a retrieval system or transmitted in any form or by any means, electronic, mechanical, photocopying, recording or otherwise, without prior permission of Heliospectra AB.

©2011–2022 by Heliospectra AB. All rights reserved.

Precautions



Our product is an advanced and safe LED fixture. However, for proper operation and for your safety, please read and follow the below precautions:

When unpacking the luminaire make sure to have a sturdy surface to work on. Damage to the unit can occur if dropped.

Do not immerse the fixture in water or clean the fixture with a high pressure water jet or strong detergents.

Never operate the fixture with the lens directly on a flat surface (e.g. table) as this may damage the lens. A minimum distance of 0.2m/8in should be kept to other objects.

The product is for indoor use only.

Always allow a free flow of air around the fixture.

This fixture may only be serviced by a trained technician. In the case of a suspected malfunction contact your distributor or Heliospectra directly.

The light source contained in this luminaire shall only be replaced by the manufacturer or his service agent or a similar qualified person.

The luminaire should be positioned so that prolonged staring into the luminaire at a distance closer than 1 meter/ 40 inches is avoided.

Do not stare into the light source. LED grow lights may contain potentially harmful light radiation. Please use UV blocking eye-wear when working in and around the illuminated area.

Only connect the fixture to properly grounded mains that complies with the voltage rating on the fixture (see power label).

Only operate the fixture with an undamaged power cord, power plug and electrical outlet.

Never unplug the fixture by pulling on the power cord.

For proper performance of the unit the ambient air temperature shall be no higher than 40° C.



Le produit est un appareil moderne et sûr. Mais pour une bonne utilisation et pour votre sécurité, veuillez lire les informations ci-dessous :

Quand vous déballez le luminaire assurez-vous d'avoir une surface solide sur laquelle travailler. L'appareil peut être endommagé si on le fait tomber.

N'immergez pas l'appareil dans l'eau et n'essayez pas de le nettoyer avec un jet d'eau à haute pression.

Ne pas mettre en marche l'appareil avec la lentille posée à plat sur quelque surface (par exemple : une table), cela pourrait l'endommager.

Le produit ne s'utilise qu'en intérieur.

Assurez-vous qu'il y ait un minimum d'air autour de l'appareil.

Cet appareil ne peut être entretenu que par un technicien expérimenté. Si vous avez un soupçon sur le mauvais fonctionnement de celui-ci, contactez votre distributeur ou Heliospectra directement.

La source de lumière contenue dans ce luminaire ne doit être remplacée que par le fabricant ou ses agents de services ou une personne similaire qualifiée pour le faire.

Le luminaire doit être positionné de telle sorte que le fixer longuement à une distance d'1 mètre/ 40 pouces soit évité.

Ne pas fixer la source de lumière. Les éclairages LED pourraient potentiellement contenir des radiations lumineuses nocives. Portez des lunettes anti-rayons UV quand vous travaillez sous ou à proximité de l'endroit éclairé.

Ne connectez l'appareil que sur une prise reliée à la terre et dont le voltage correspond à celui de l'appareil.

L'appareil doit être mis en marche avec rien d'autre qu'une prise, un cordon électrique ou une prise secteur non endommagés.

Ne jamais déconnecter l'appareil en tirant sur le cordon électrique.

Pour une utilisation optimale de l'appareil, la température ambiante ne doit pas dépasser 40°C.

Table of Contents

1.	PRODUCT OVERVIEW	5
1.1	MITRA SQUARE (MI65SF, MI65SV, MI65SB)	5
1.2	MITRA LINEAR (MI65LF, MI65LV, MI65LB)	6
1.3	MITRA SPLIT (MI65LFS, MI65LVS, MI65LBS)	7
1.4	Technical Specifications	8
2.	PSU OVERVIEW	10
2.1	PSU 0-10V Dimming (MIPSU01)	10
2.2	PSU Flex (MIPSU03)	11
	PSU 0-10V Dimming B (MIPSU04)	11
2.3	Technical Specifications	12
3.	MOUNTING INSTRUCTIONS	14
3.1	MITRA Square (MI65SF, MI65SV, MI65SB)	14
3.2	MITRA Linear (MI65LF, MI65LV, MI65LB)	15
3.3	MITRA Split (MI65LFS, MI65LVS, MI65LBS)	15
3.4	PSU 0-10V Dimming (MIPSU01)	16
3.5	PSU Flex & PSU 0-10V Dimming B (MIPSU03, MIPSU04)	16
4.	ELECTRICAL INSTALLATION	17
4.1	Lamp Connection	17
4.2	Power Connection	17
4.2.1	Surge Protection	17
4.3	Dimming	19
4.3.1	2-Wire Cable (MIPSU01, MIPSU04)	19
4.3.2	4-Wire Cable (MIPSU03)	20
5.	MAINTENANCE	22
5.1	Cleaning	22
5.2	Disposal	22
6.	GENERAL WARRANTY TERMS AND CONDITIONS	23
6.1	Warranty	23
6.2	Terms and Conditions	24
6.2.1	Electrical Installation Quality Requirements and Conditions	24
6.2.2	Surge Protection Requirements	24
6.2.3	Warranty Limitations	25
6.2.4	Warranty Claim Process	26
6.3	Implied or Other Warranties	28
6.4	Disclaimers	28

1. Product Overview

1.1 MITRA Square (MI65SF, MI65SV, MI65SB)

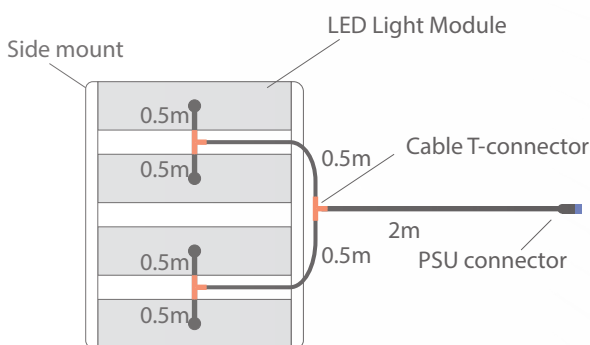
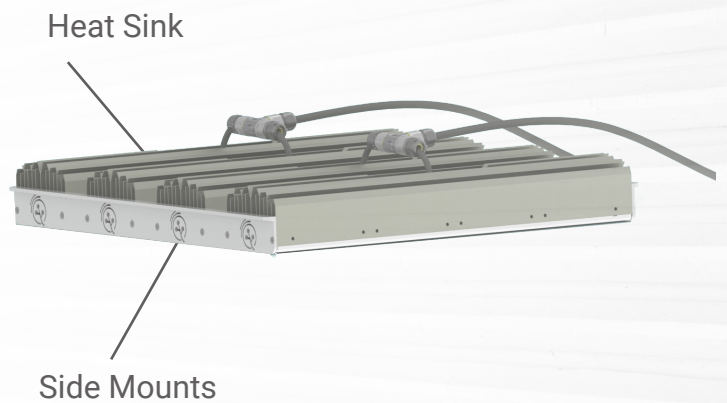
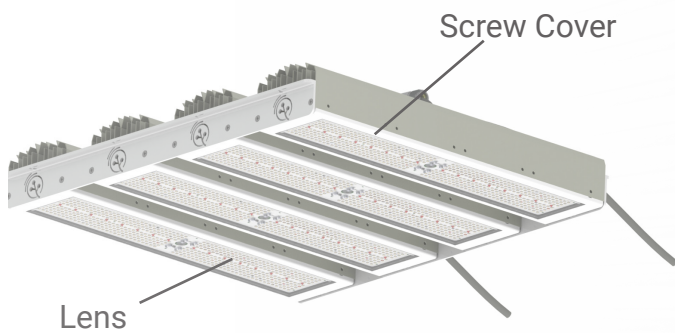

Square configuration

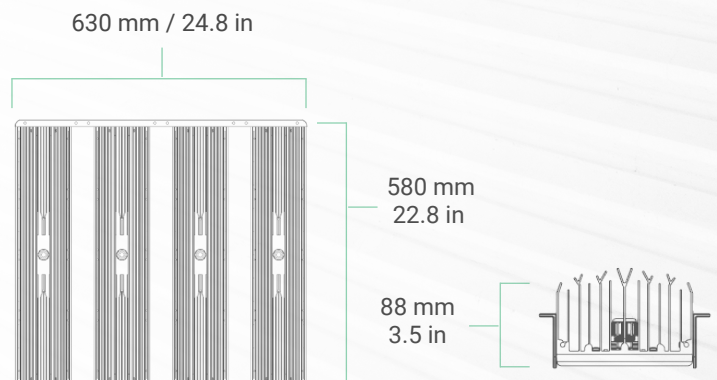

Top view

Front view

NOTE!

When unpacking and installing your MITRA make sure to have a sturdy surface to work on. Damage can occur to the light bar if dropped.

1.2 MITRA Linear (MI65LF, MI65LV, MI65LB)

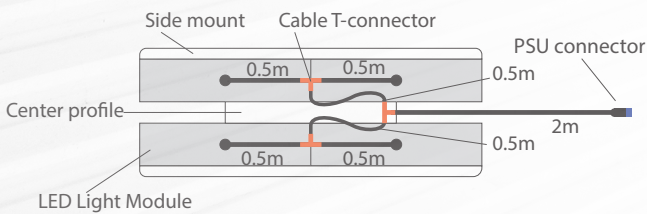
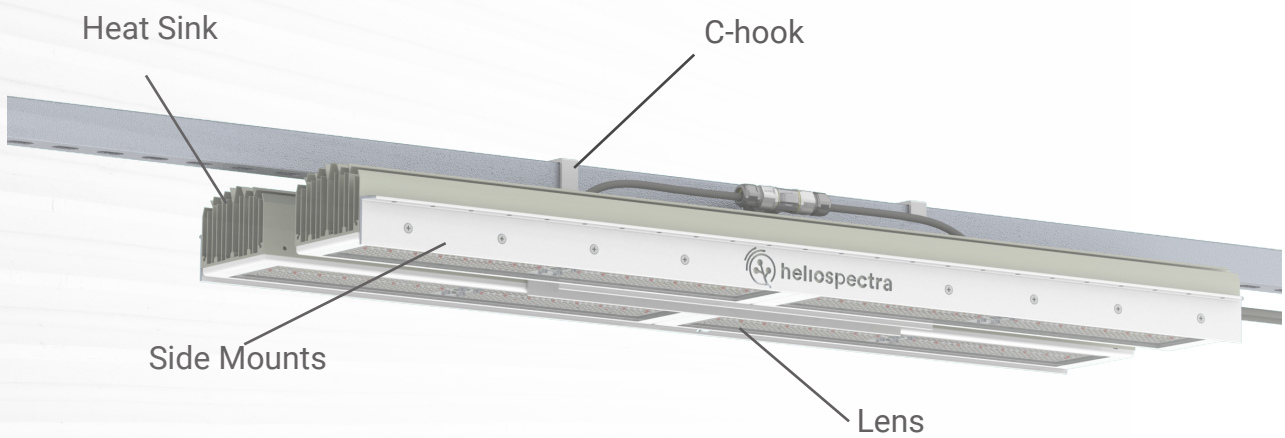

Linear configuration

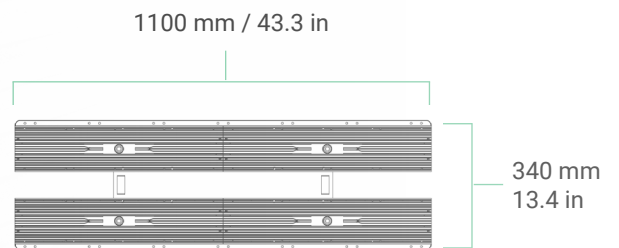

Top view

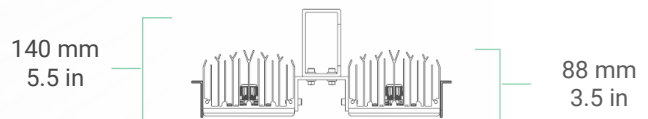

Front view

NOTE!

When unpacking and installing your MITRA make sure to have a sturdy surface to work on. Damage can occur to the light bar if dropped.

1.3 MITRA Split (MI65LFS, MI65LVS, MI65LBS)

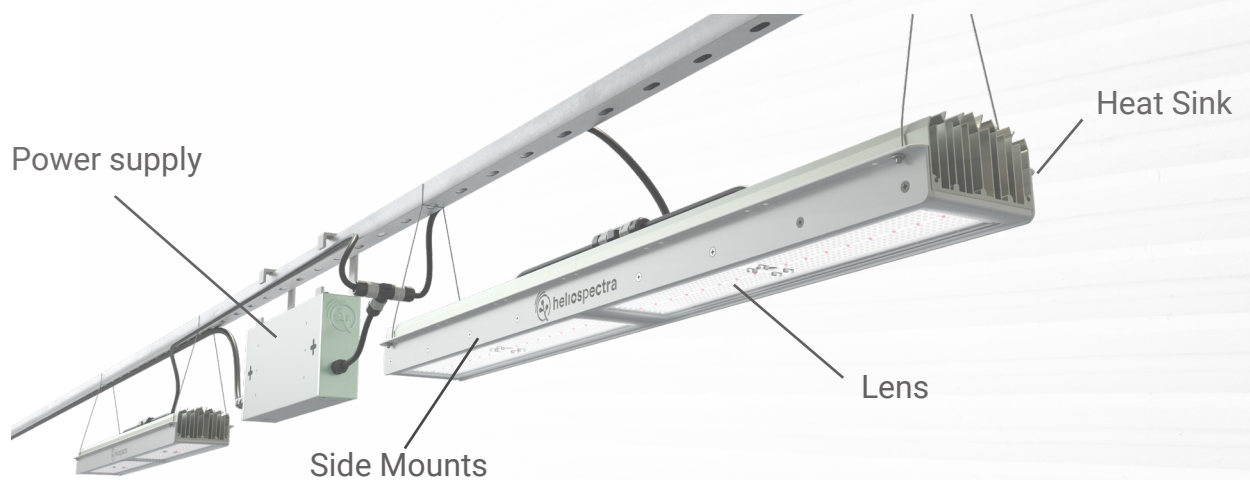

1100 mm / 43.3 in



Top view

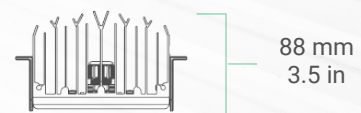

Front view

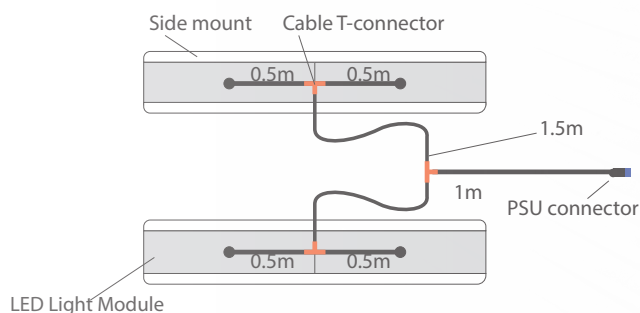

Split configuration

*the width is given for one of the two lamp modules

NOTE!

When unpacking and installing your MITRA make sure to have a sturdy surface to work on. Damage can occur to the light bar if dropped.

1.4 Technical Specifications

	MITRA SQUARE (MI65SF, MI65SV, MI65SB)	MITRA LINEAR (MI65LF, MI65LV, MI65LB)
Physical		
Size (LxWxH)	580 x 630 x 88 mm (22.8 x 24.8 x 3.5 in)	1100 x 340 x 88 mm (43.3 x 13.4 x 3.5 in)
Weight	12 kg (26.5 lbs) excl. power supply	13,5 kg (29.8 lbs) excl. power supply
Mounting	Hole Profile	C-Bracket
Electrical		
PSU Compatability	MIPSU01, MIPSU03, MIPSU04	MIPSU01, MIPSU03, MIPSU04
Typical Power Consumption	0-650 W	0-650 W
General		
Temperature	Operating: -10-40°C (14-104 F) Storage: -20-70°C (-4-158 F)	Operating: -10-40°C (14-104 F) Storage: -20-70°C (-4-158 F)
Heat Value (BTU/h)	Up to 2218 BTUs/h	Up to 2218 BTUs/h
IP Rating	IP67	IP67
Lifetime	>46 000 h (rated life to 90% of initial photon flux)	>46 000 h (rated life to 90% of initial photon flux)
Controllable	0-10VDC, 10V PWM signal or WiFi* (depending on PSU)	
Cooling	Passive - Convection cooled	Passive - Convection cooled
Housing Material	ABS plastic and Anodized Aluminum Diffuser : Highly transmissive acrylic glass	ABS plastic and Anodized Aluminum Diffuser : Highly transmissive acrylic glass
Compliance	CE, cETLus, and Damp Location	CE, cETLus, and Damp Location

*Requires the Adelphi wireless connector

	MITRA SPLIT (MI65LFS, MI65LVS, MI65LBS)
Physical	
Size (LxWxH)*	1100 x 140 x 88 mm (43.3 x 5.5 x 3.5 in)
Weight	13.5 kg (29.8 lbs) excl. power supply
Mounting	Hole Profile
Electrical	
PSU Compatability	MIPSU01, MIPSU03, MIPSU04
Typical Power Consumption	0-650 W
General	
Temperature	Operating: -10-40°C (14-104 F) Storage: -20-70°C (-4-158 F)
Heat Value (BTU/h)	Up to 2218 BTUs/h
IP Rating	IP67
Lifetime	>46 000 h (rated life to 90% of initial photon flux)
Controllable	0-10VDC, 10V PWM signal or WiFi** (de- pending on PSU)
Cooling	Passive - Convection cooled
Housing Material	ABS plastic and Anodized Aluminum Diffuser : Highly transmissive acrylic glass
Compliance	CE, cETLus, and Damp Location

*the width is given for one of the two lamp modules

**Requires the Adelphi wireless connector

2. PSU Overview

2.1 PSU 0-10V DIMMING (MIPSU01)

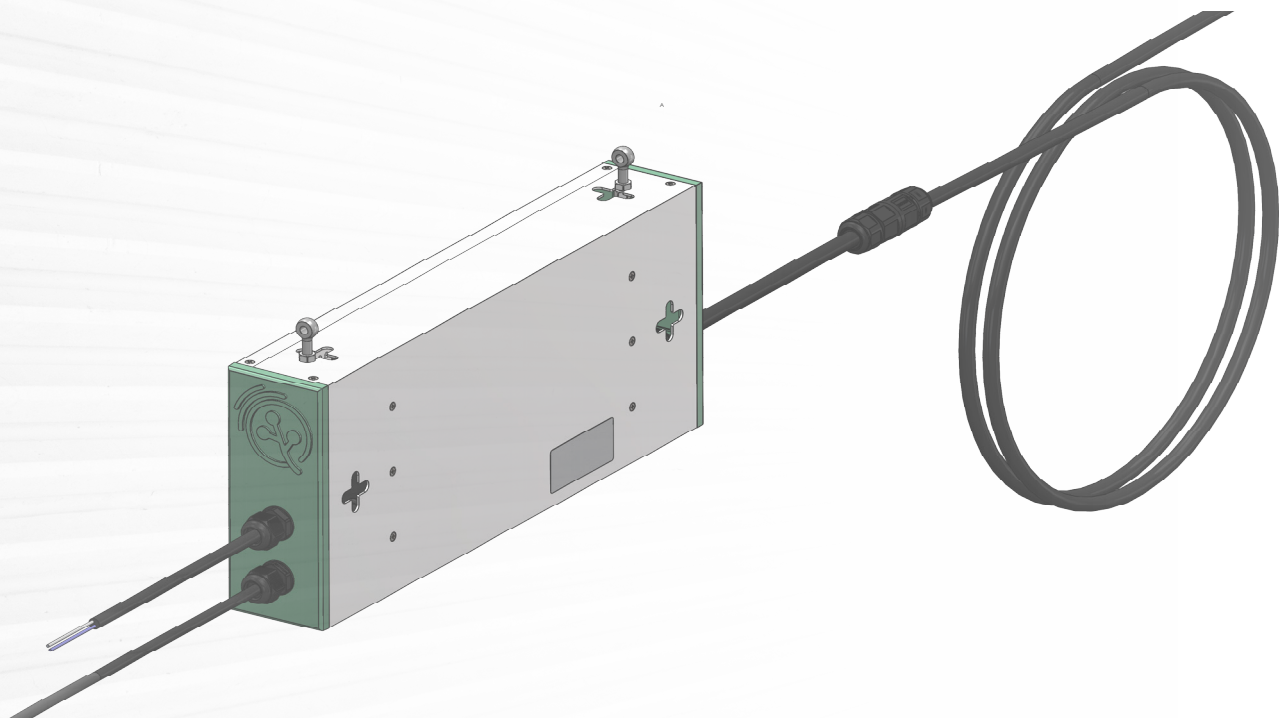

70 mm / 2.8 in



Side view

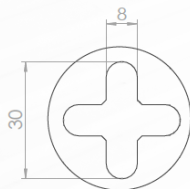

Plus hole

180 mm / 7.1 in

1800 mm / 70.9 in

Power Cable

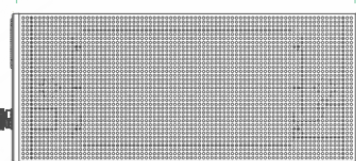

Front view

426 mm / 16.8 in

Lamp Cable

200 mm / 7.9 in

300 mm / 11.8 in

Dimming Cable

2.2 PSU Flex (MIPSU03) & PSU 0-10V DIMMING B (MIPSU04)



Top view

210 mm /
8.3 in

60 mm / 2.4 in

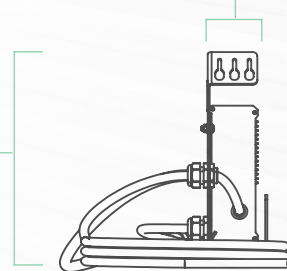

Side view

380 mm / 15 in

Power Cable
1800 mm / 70.9 in

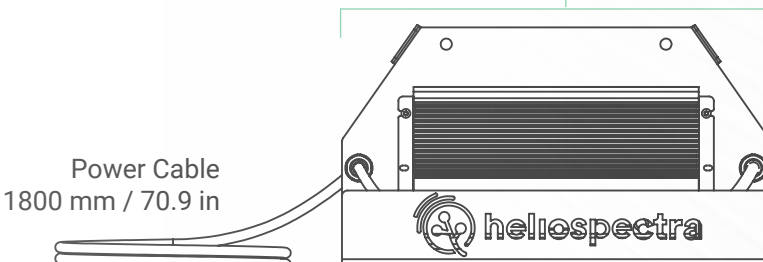

Front view

Lamp Cable
200 mm / 7.9 in (MIPSU04)
500 mm / 19.7 in (MIPSU03)

Dimming Cable
300 mm / 11.8 in

2.3 Technical Specifications

	PSU 0-10V DIMMING (MIPSU01)	PSU FLEX (MIPSU03)
Physical		
Size (LxWxH)	426 x 180 x 70 mm (16.8 x 7.1 x 2.8 in)	380 x 210 x 60 mm (15.0 x 8.3 x 2.4 in)
Weight	6 kg (13.2 lbs) excl. power supply	4 kg (8.8 lbs) excl. power supply
Mounting	Plus holes	Chain
Electrical		
Voltage Range	200 - 480 VAC	200 - 480 VAC
Frequency	50/60 Hz	50/60 Hz
Typical Power Consumption	0-650 W	0-650 W
General		
Temperature	Operating: -10-40°C (14-104 F) Storage: -20-70°C (-4-158 F)	Operating: -10-40°C (14-104 F) Storage: -20-70°C (-4-158 F)
IP Rating	IP67	IP67
Lifetime	>218 000 hrs	>218 000 hrs
Controllable	0-10VDC or 10V PWM signal	0-10VDC, 10V PWM signal or WiFi*
Cooling	Passive - Convection cooled	Passive - Convection cooled
Housing Material	ABS plastic and Anodized Aluminum	Anodized Aluminum
Compliance	CE, cETLus, and Damp Location	CE, cETLus, and Damp Location

*Requires the Adelphi wireless connector

PSU 0-10V DIMMING B (MIPSU04)	
Physical	
Size (LxWxH)	380 x 210 x 60 mm (15.0 x 8.3 x 2.4 in)
Weight	4 kg (8.8 lbs) excl. power supply
Mounting	Chain or C-hook*
Electrical	
Voltage Range	200 - 480 VAC
Frequency	50/60 Hz
Typical Power Consumption	0-650 W
General	
Temperature	Operating: -10-40°C (14-104 F) Storage: -20-70°C (-4-158 F)
IP Rating	IP67
Lifetime	>218 000 hrs
Controllable	0-10VDC or 10V PWM signal
Cooling	Passive - Convection cooled
Housing Material	Anodized Aluminum
Compliance	CE, cETLus, and Damp Location

3. Mounting Instructions

The support structure needs to be sturdy enough to support the weight of the MITRA lamps, their power supply and any additional equipment. None of the power cables can be used to support the weight of the fixture.

Air must be able to flow freely around the MITRA fixture and power supply, they are cooled using passive, convection cooling.

NOTE. Heliospectra's recommendation for installations using chain:

- Welded chain with a diameter of 2-3 mm (1/16 - 1/8 in)
- Working load limit: Minimum 4 times the total weight of the equipment

3.1 MITRA Square (MI65SF, MI65SV, MI65SB)



Hole Profile

MITRA Square fixtures are equipped with a hole profile from which the fixture can be hung off-the-shelf hooks and chains.

The hole diameter is 5 mm (0.19 in).

NOTE: I-hooks and chains are not included.

3.2 MITRA Linear (MI65LF, MI65LV, MI65LB)

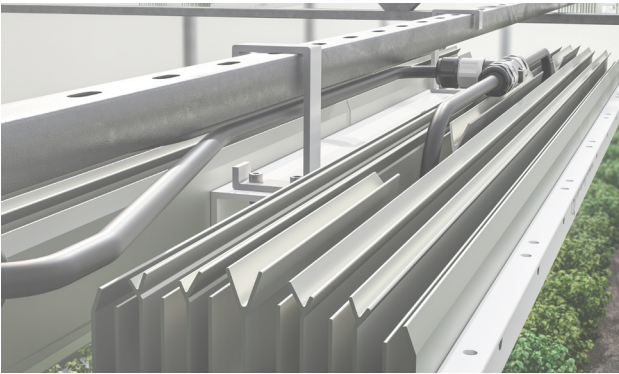

Pre-mounted C-brackets

MITRA Linear fixtures are delivered with pre-mounted C-brackets for mounting from Unistrut profiles or similar.

The inner width of the C-bracket is 42 mm (1.65 in).

3.3 MITRA Split (MI65LFS, MI65LVS, MI65LBS)



Hole Profile

MITRA Split fixtures are equipped with a hole profile from which the fixture can be hung with off-the-shelf chains/wires and hooks.

The hole diameter is 5 mm (0.19 in).

3.4 PSU 0-10V Dimming (MIPSU01)

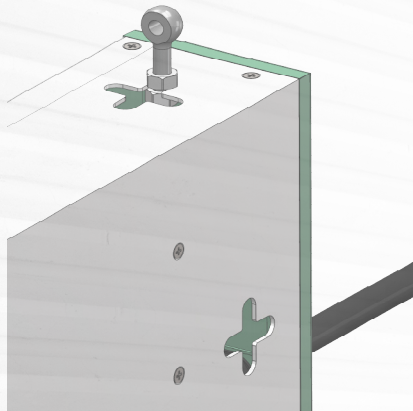

Cross Hole profile

PSU 0-10V Dimming (MIPSU01) has pre-cut holes on the top and the back to allow for fitting a hanging apparatus of your choice. Make sure to use both holes on the top or both holes at the back so that the power supply unit is equally suspended from both ends.

Note: I-hooks are not included.

3.5 PSU Flex (MIPSU03) & PSU Dimming B (MIPSU04)

Chain Mounting Profile

PSU Flex (MIPSU03) and **PSU 0-10V Dimming B (MIPSU04)** have backplates which are prepared for mounting with off-the-shelf chains. Make sure to select a chain of such quality that it can support four times the load from the PSU.

The maximal chain diameter is 3 mm (0.12 in).

Note: Chains are not included.



One-point chain mounting.



Two-point chain mounting.

4. Electrical Installation

4.1 Lamp Connection

The PSUs lamp cable is equipped with a larger, black quick connector which should be connected to the lamps PSU connector.

4.2 Power Connection

The PSUs input power cable is open ended with three internal cables:

- Blue: Neutral / N
- Brown: Phase 1 / L
- Green and Yellow: Protective earth / ground

NOTE!

All electrical installation should be done by a qualified electrician.

4.2.1 Surge Protection

Heliospectra AB requires that the fixtures are installed with adequate surge protection according to the local recommended practice. In North America IEEE 1100-2005 contains the recommended practice for powering and grounding electronic equipment. In Europe the applicable standard is IEC 62305 – Protection Against Lightning. If you are outside of North America or Europe please use your local standard.

All installations should utilize surge protection devices (SPDs), to provide maximum protection regardless of the source of the surge. The three zones include:

- The first zone is at the service entrance where the most robust SPD is placed to divert surges coming from external sources such as lightning. SPDs installed here are listed as Type-1, SPD devices.
- The second zone of protection is within the facility at locations identified as susceptible to surges. SPDs at these locations are listed as Type-2, SPD devices and are installed on equipment such as switchboards, panel-boards, motor-control centers.
- The third zone of protection is at the outlet or point of use. SPDs installed here are listed as Type-3, SPD devices.

It is required that a professional engineer, experienced with surge suppression technology, be retained to design the protection system for your facility to ensure all SPDs are properly sized and coordinated.

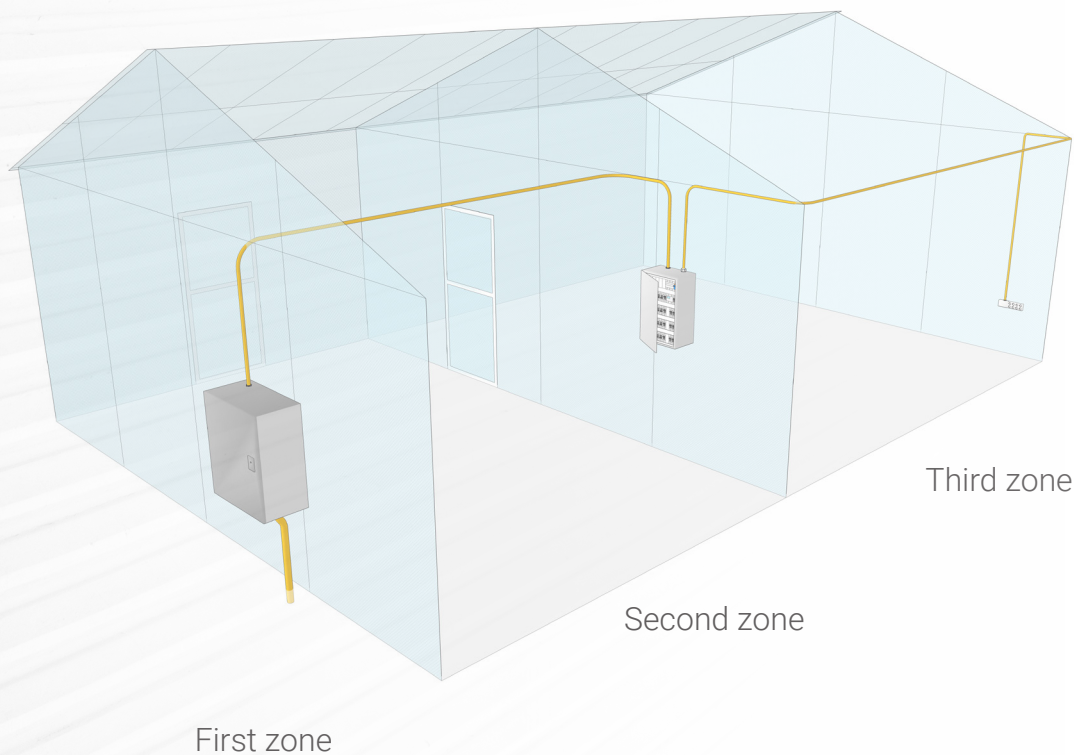

4.3 Dimming

4.3.1 2-Wire Cable (MIPSU01, MIPSU04)

The dimming cable has a black connector which is meant to be connected to your preferred dimming solution. This cable has two internal wires for dimming:

- Blue:** DIM+
- White:** DIM-

■ DIMMING OPERATION

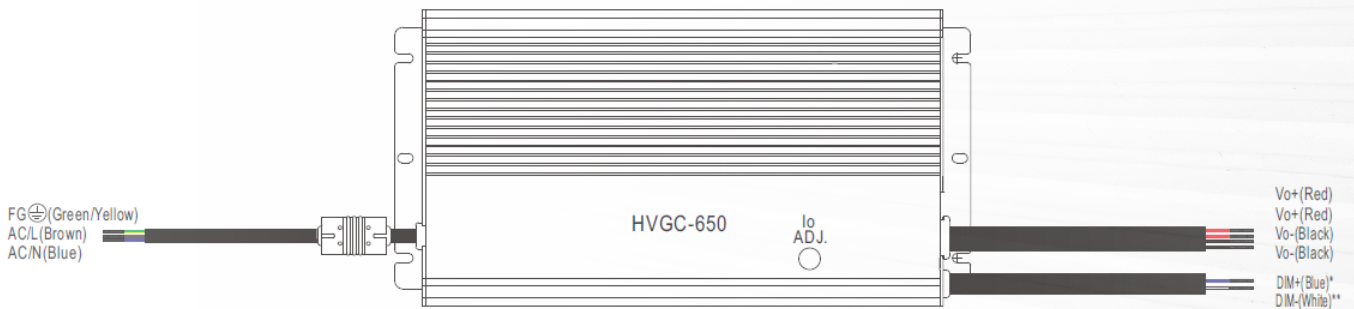

※ 3 in 1 dimming function (for Blank-Type)

- Output constant current level can be adjusted by applying one of the three methodologies between DIM+ and DIM-: 0 ~ 10VDC, or 10V PWM signal or resistance.
- Direct connecting to LEDs is suggested. It is not suitable to be used with additional drivers.
- Dimming source current from power supply: 100 μ A (typ.)

◎ Applying additive 0 ~ 10VDC

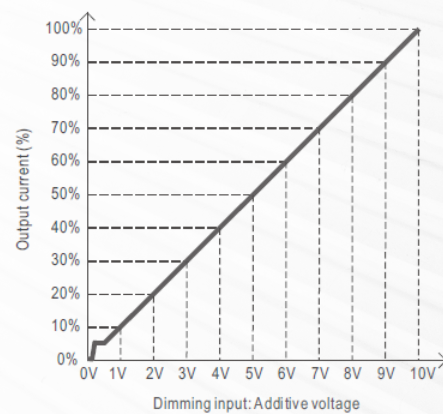
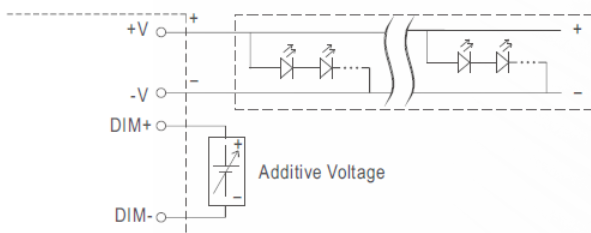

© Applying additive 10V PWM signal (frequency range 100Hz ~ 3KHz):

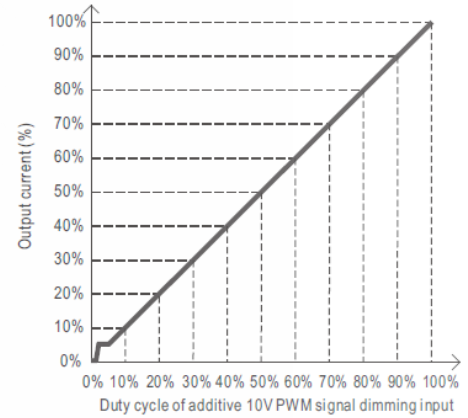
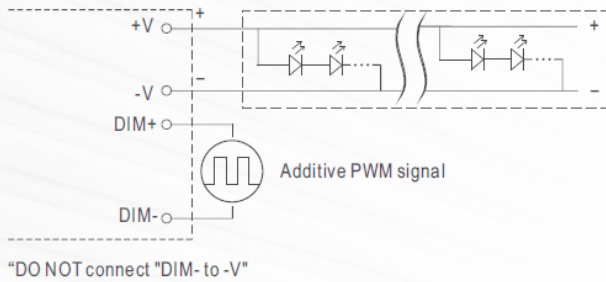

© Applying additive resistance:

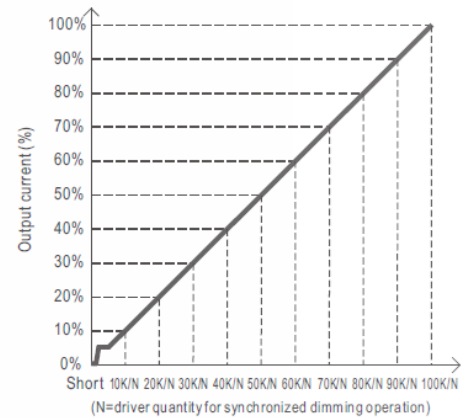
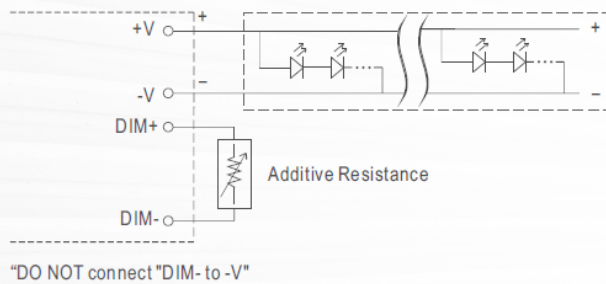

4.3.1 4-Wire Cable (MIPSU03)

The dimming cable has a black quick connector which is meant to be connected to your preferred dimming solution. This cable has four internal wires, two for dimming and two for an extra supply of your dimming equipment. The supply is at a 12v and is limited to 200mA of current.

Pinout of DIM connector:

1. DIM+
2. DIM-
3. +12V AUX
4. GND AUX

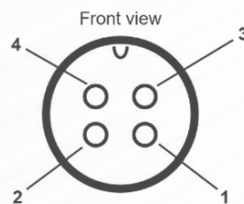

DIMMING OPERATION

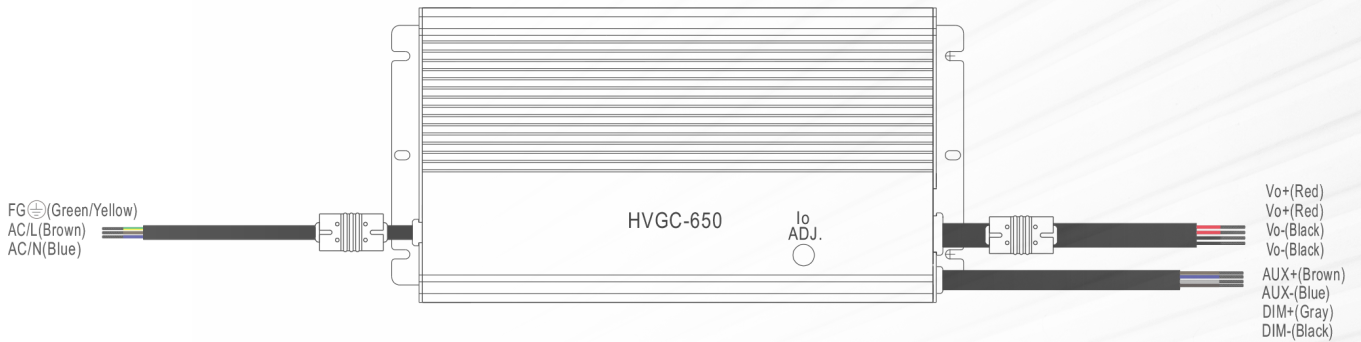

※ 3 in 1 dimming function

- Output constant current level can be adjusted by applying one of the three methodologies between DIM+ and DIM-: 0 ~ 10VDC, or 10V PWM signal or resistance.
- Direct connecting to LEDs is suggested. It is not suitable to be used with additional drivers.
- Dimming source current from power supply: 100 μ A (typ.)

◎ Applying additive 0 ~ 10VDC

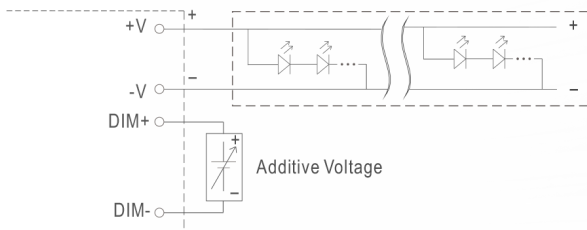

"DO NOT connect "DIM- to -V"

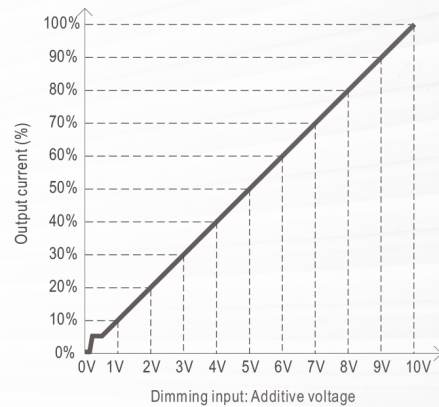

◎ Applying additive 10V PWM signal (frequency range 100Hz ~ 3KHz):

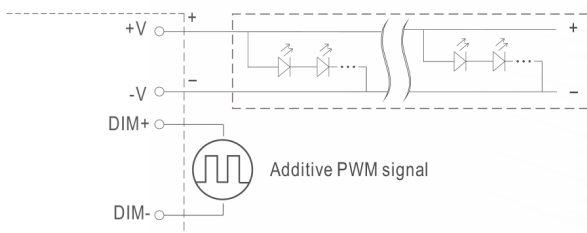

"DO NOT connect "DIM- to -V"

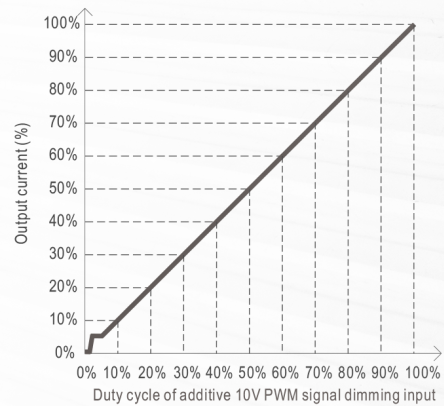

◎ Applying additive resistance:

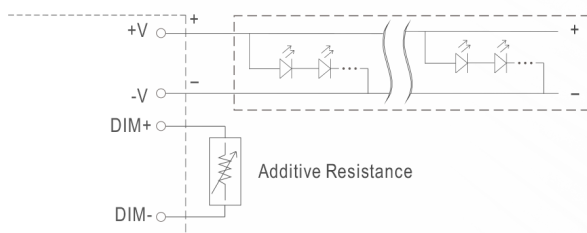

"DO NOT connect "DIM- to -V"

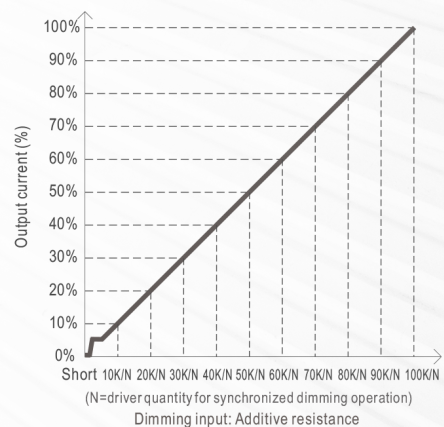

Note : 1. Min. dimming level is about 6% and the output current is not defined when 0% < Iout < 6%.

2. The output current could drop down to 0% when dimming input is about 0k Ω or 0Vdc, or 10V PWM signal with 0% duty cycle.

5. Maintenance

5.1 Cleaning

To ensure optimal performance and lifespan of the lamp it is important to clean regularly. If you see a build up of dirt or residue anywhere on the MITRA lamp, this needs to be cleaned.

To clean the MITRA most effectively please follow these simple steps.

1. Make sure the fixture is turned off and not connected to the mains power.
2. Light dust and dirt can be cleaned with low-pressure compressed air.
3. More heavily polluted fixtures could be cleaned with a soft cloth using water and soap.
4. Wipe everything dry, or let the fixture dry fully by itself before reconnected to the mains power.

DO NOT(!) disassemble the MITRA lamp in order to clean it, it is not necessary, and disassembling it will invalidate your warranty.

5.2 Disposal



This symbol on the product(s) and / or accompanying documents means that used electrical and electronic products should not be mixed with general household waste. For proper treatment, recovery, and recycling, please take this product(s) to designated collection points where it will be accepted free of charge.

Disposing of this product correctly will help save valuable resources and prevent any potential negative effects on human health and the environment, which could otherwise arise from inappropriate waste handling.

Please contact your local authority for further details of your nearest designated collection point. Penalties may be applicable for incorrect disposal of this waste, in accordance with your national legislation.

For business users in the European Union

If you wish to discard electrical and electronic equipment, please contact your dealer or supplier for further information.

Information on Disposal in other Countries outside the European Union

This symbol is only valid in the European Union. If you wish to discard this product, please contact your local authorities or dealer, and ask for the correct method of disposal.

6. General Warranty Terms and Conditions

6.1 Warranty

Heliospectra top lights carry a warranty that the hardware components of Heliospectra Products will be free from defects in material and workmanship for a period of five (5) years for the MITRA series and three (3) years for other products, from the date of delivery. The warranty extends only to the original Buyer of the Product and may not be transferred or assigned by the original Buyer.

The warranty only applies to sales directly through Heliospectra or any authorized reseller. If the Product was purchased through an authorized reseller, the same terms shall apply, but any claim shall be made via the reseller who sold the Products to the original Buyer.

If the Product fails to comply with the terms of this warranty, Heliospectra, at its option, will repair and return the original unit or provide a reconditioned unit as a replacement. The warranty excludes labor and equipment required to remove and/or reinstall original or replacement parts. Warranty claims must be reported and returned to Heliospectra within the warranty period and no later than thirty (30) days after discovery of the suspected defect. All warranty claims must be submitted in writing and have gone through the official Heliospectra Return Material Authorization (RMA) process. If Heliospectra chooses to replace the Product and is not able to do so because it has been discontinued or is not available, Heliospectra may refund the Buyer or replace the Product with a comparable Product.

Any non-Heliospectra equipment or products that have been acquired through a Heliospectra purchase are not covered under this warranty, but instead will carry the manufacturer's standard warranty.

Heliospectra shall pay for shipping costs for valid warranty claims. The Buyer is responsible for the shipping costs associated with returning the Product to Heliospectra if the warranty is voided or otherwise rejected.

If applicable, software warranty and any instructions thereto will be provided to the Buyer separately. If applicable, Heliospectra warrants that embedded software in the Product shall perform substantially in accordance with the specifications contained in the applicable Product manual under normal authorized use and in accordance with instructions provided by Heliospectra. In no event does Heliospectra warrant that the software is error free or that the Buyer will be able to operate the software without problems or interruptions. Heliospectra does not give any warranty for third party software (meaning herein software created by other parties than Heliospectra) and Heliospectra shall not be liable for any damages possibly caused by failures in third party software or caused by changes in the software by the Buyer or anyone other than an authorized Heliospectra technician.

Heliospectra shall have no liability for any claim, suit or proceeding of infringement based on (a) the use of other than the then latest release of software provided by Heliospectra, if such infringement could have been avoided by the use of the latest available release of software or (b) the use or combination of Product with software, hardware or other materials not provided, not recommended or approved by Heliospectra.

6.2 Terms and conditions

6.2.1 Electrical Installation Quality Requirements and Conditions

Heliospectra requires that the installation of the Product is conducted by a licensed electrician with adequate surge protection according to the requirements below. If the surge protection requirement is not implemented, a proof of electrical quality reading must be performed by a third party and presented as proof of adequate electrical quality.

6.2.2 Surge Protection Requirements

NORTH AMERICA

Heliospectra requires that Products are installed with adequate surge protection according to the IEEE 1100-2005 recommended practice for Powering and Grounding Electronic Equipment. Considering that surges can originate from both internal and external sources, surge protection devices ("SPDs") are to be installed to provide maximum protection regardless of the source location. The three zones include:

- The first zone is at the service entrance where the most robust SPD is placed to divert surges coming from external sources such as lightning. SPDs installed here are listed as Type-1, SPD devices.

- The second zone of protection is within the facility at locations identified as susceptible to surges. SPDs at these locations are listed as Type-2, SPD devices and are installed on equipment such as switchboards, panelboards, motor-control centers.
- The third zone of protection is at the outlet or point of use. SPDs installed here are listed as Type-3, SPD devices.

EUROPE

Heliospectra requires that all fixtures should be protected by adequate surge protection, in accordance with the following standard: IEC 62305 – Protection Against Lightning. This standard stipulates the following:

- SPDs (Surge Protection Devices) should be installed when crossing from one lightning protection zone to another
- Lightning is not the only threat; switching of loads, which are more frequent than lightning strikes, also create high voltage transients that can damage electrical or electronic equipment over time.
- Risk assessments are required to be carried out to assess the requirements of any building for SPDs.
- Ensure that the 3 Lightning Protection Zones (LPZ) zones and types 1, 2, 3 of Surge Protection Devices are used correctly.

For other installation locations, please advise local electrical standards that are equivalent

6.2.3 Warranty Limitations

This warranty does not apply under any of the following circumstances:

- a. The Product has been opened or altered by anyone other than Heliospectra or an authorized representative
- b. The Product has not been installed (including proper electrical and WiFi equipment and installation), operated or maintained in accordance with instructions supplied by Heliospectra
- c. The Product has developed defects due to damage in transport, storage or any other circumstances that are beyond the immediate control of Heliospectra
- d. The Product has been installed in applications outside the operating intervals in the product specification

- e. The Product has been damaged, defaced, exposed to corrosive environment, subjected to misuse or vandalism, abnormal service or handling or by any other circumstances attributable to the Buyer, its buyers, end-users or any third party
- f. The Product is licensed for beta, evaluation, testing or demonstration purposes
- g. The Product has been repaired or attempted to be repaired by anyone other than Heliospectra or a Heliospectra authorized representative
- h. The Product has been subjected to natural disasters that have caused defects such as lightning strikes, floods, hurricanes, earthquakes, etc.
- i. The Product has been subjected to electric line power surges, unstable electrical supply conditions, ripple current or other electrical infrastructure malfunctions
- j. The Product has not been installed by a licensed electrician with adequate surge protection.
- k. For MITRA LED components: 85% or more of the light emitting diodes illuminate.

Heliospectra reserves the right to make the final decision on the validity of any warranty claim.

6.2.4 Warranty Claim Process

Before returning any Product, a Return Material Authorization (“RMA”) reference number must be obtained from Heliospectra. A reference number is obtained by completing an RMA form and provided by Heliospectra once the validity of the claim is preliminarily assessed by Heliospectra.

The claim process depends on A) Warranty is valid or B) Warranty is voided

- A.** If a claim is made within the warranty period and none of the warranty limitations described above have been breached, then
 - a. Heliospectra will arrange for retrieval of the fixture(s) from the customer location
 - b. A failure analysis will be conducted at the Heliospectra Repair Center. If the agent at the repair center finds that the cause of the issue is attributed to one or more of the warranty limitations/exclusions described above, the warranty will be deemed as void and the process will be handled as described in column B after informing the customer
 - c. The fixture(s) will be repaired according to the failure analysis
 - d. The fixture(s) will be returned to the customer along with the failure analysis report and a description of the repairs made to the unit(s)
 - e. No cost will be attributed the customer

- B.** If the warranty period has lapsed or the warranty has been voided due to one of more of the warranty limitations/exclusions described above, then
- a. A cost estimate of the shipping and repairs will be first sent for approval to the customer
 - b. Upon approval, Heliospectra will retrieve the fixture(s) from the customer location
 - c. A failure analysis will be conducted at the Heliospectra Repair Center
 - d. An updated final cost of repairs along with the failure analysis will be sent to the customer for approval to move forward
 - e. The fixture(s) will then be repaired according to the failure analysis
 - f. A final invoice will be sent to the customer for the repair service and shipping
 - g. Upon receipt of payment from customer, the fixture(s) will be returned to the customer along with the failure analysis report and a description of the repairs made to the unit(s)

The official Heliospectra Return Material Authorization (RMA) process is initiated by submitting an online support request per instructions found at <https://support.heliospectra.com/portal/home>.

The following is required by Heliospectra to complete an RMA assessment:

1. Date of purchase
2. Product designation and number
3. Product serial number
4. Description of defect and occurrence
5. Adequate records of operating history, maintenance, and/or testing to substantiate that the Product has failed to comply with its intended performance
6. Original or equivalent packaging to ship the unit(s) to the Heliospectra Repair Center

6.3 Implied or Other Warranties

Except as otherwise expressly set forth in these Warranty Terms and Conditions, Heliospectra, on behalf of itself and its affiliates disclaim all other warranties whether expressed, implied or statutory regarding or relating to the hardware, documentation, software, media or the services furnished or provided to the customer. HELIOSPECTRA SPECIFICALLY DISCLAIMS ALL IMPLIED WARRANTIES OF MERCHANTABILITY AND FITNESS FOR A PARTICULAR PURPOSE.

Neither sales personnel of Heliospectra nor any other persons are authorized to make any warranties other than those described in this document, or to extend the duration of any warranties beyond the period described in this document except an authorized officer and pursuant to signed documents.

6.4 Disclaimers

To the full extent permitted by law, Heliospectra will not be liable to the Buyer for any loss or damage arising from the use of the Product, or any defect in the Product, however it may arise. Apart from the warranties as stated above, Heliospectra has no obligation to provide support, maintenance, upgrades, modifications or new releases. Heliospectra disclaims all liability and responsibilities pertaining to and arising as a result of the Buyer integrating, connecting or networking the Product in any manner whatsoever. If technical support is offered regarding the use or implementation of the Product that is outside or contrary to official Heliospectra documentation, it will solely be as an accommodation to the Buyer and Heliospectra holds no responsibilities or liabilities for the content or use of such advice.

IN NO EVENT WILL HELIOSPECTRA BE LIABLE FOR ANY SPECIAL, CONSEQUENTIAL, INDIRECT OR INCIDENTAL LOSS OR DAMAGE OF ANY KIND OR ANY DIRECT LOSS. HELIOSPECTRA'S LIABILITY ARISING OUT OF PRODUCT WILL BE LIMITED TO AN AMOUNT EQUAL TO THE INITIAL PURCHASE PRICE OF THE PRODUCT.

THE ABOVE STATE HELIOSPECTRA'S ENTIRE RESPONSIBILITY AND BUYER'S SOLE AND EXCLUSIVE REMEDY WITH RESPECT TO ANY BREACH OF ANY WARRANTY REGARDING THE HARDWARE AND SOFTWARE.

Version 2022-05-13.



Contact Details

Got questions? Or need info related to how to set your new MITRA?
Visit our Support Portal for User Manuals, articles and videos. <https://support.heliospectra.com/portal/en/home>

Or sent our dedicated support team an email at support@heliospectra.com

UK Authorised Representative: Comply Express Ltd, Unit C2, Coalport House, Stafford Park 1, Telford TF3 3BD, United Kingdom

OUR OFFICES

Sweden

Heliospectra AB.
Fiskhamngatan 2,
414 58, Gothenburg
+46 31 40 67 10

Canada

Heliospectra Canada Inc.
2 Bloor Street West
Suite 2120
ON M4W 3E2, Toronto
+1 888-942-GROW

United States

Heliospectra Inc.
1658 N. Milwaukee Avenue
Suite #100-6558
60647 Chicago, Illinois
+1 888-942-GROW

Japan

Heliospectra Japan Co., Ltd.
2-10-3 Terada Kojimachi Build.
Chiyoda-ku, 102-0083, Tokyo
+81(0)90-1432-1993

